

## Fully Integrated Ready-to-use System for Telecom

# PMG-DCc

Permanent Magnet Generator  
+ DCc System  
+ Actuator kit

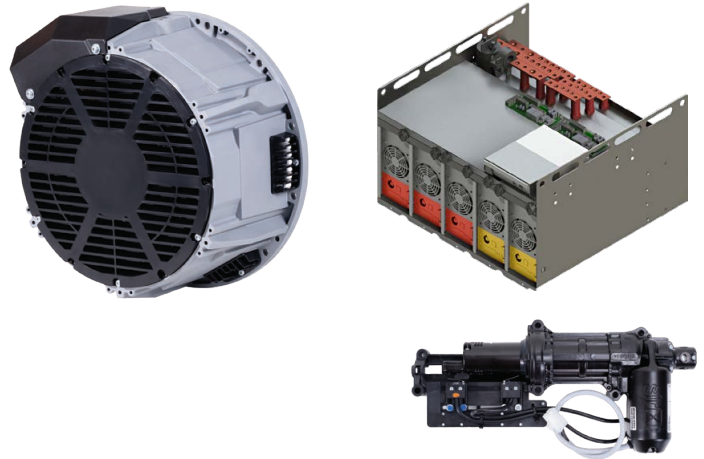

### PMG-DCc includes:

**Permanent Magnet Generator:** variable speed, 3-phase Vac output, bearingless and brushless.

**DCc System:** controller + scalable 4kW AC/DC converter modules + current sensor.

**Actuator kit:** to regulate the engine revolutions.

The system works at **variable speed** with the aim of consistently adjusting the engine speed according to the power demand of load and battery. The output voltage is independent of the engine speed and the rpm range is determined at a 1:3 ratio.

Each PMG-DCc is developed according to the specific engine model, gen-set control unit and battery pack, as it works as a battery charger thanks to the controller's smart battery management.

The settings are adjustable through a programmer, via USB pen drive or via serial connection (from the gen-set control unit).

**Grid connectable** through a transformer granting a 3-phase voltage up to 140Vac.

**Hybrid compatible** as it can host one or multiple 3,5kW DC/DC sun converter modules to work in parallel with the renewable energy source.

**Redundancy and load sharing** between two complete gen-sets operating in parallel and also between the single converter modules of the DCc system.

Digital inputs/outputs available for interfacing with other gen-set devices such as air conditioners, thermostats, water refill systems and so on (available on request).

### Technical characteristics

**Nominal voltage** 44÷60Vdc (adjustable)

**rpm Range** 1÷3 ratio (ex: 1000+3000rpm)

**Protection** IP 21 (PMG)  
IP 00 (DCc System)

**Voltage accuracy** ± 100 mV

**Voltage ripple** mV pp 150

**Battery charger current accuracy** ± 1 %

**Communication ports** RS232 / RS485 / CAN-bus

**Operating temperature** -10°C / +60°C (derating above 50°C)

#### Safety features:

- Output short circuit protection
- Output reverse voltage protection (battery) on request
- Under and over-voltage protection
- Under and over-speed protection
- Over-temperature protection
- Overload protection

Model	Output Power Range [kW]	Efficiency PMG + DCc System (*) η %	Weight			
			PMG cone [kg]	PMG SAE 4 [kg]	DCc System (**) [kg]	Actuator [kg]
PMG-DCc 185SC	4 - 12	85 - 87	16,5	15,5	25	1,6
PMG-DCc 185SF	4 - 16	85 - 87	20,5	19,5	25	1,6
PMG-DCc 295SB	8 - 20	85 - 87	-	39,5	25	1,6
PMG-DCc 295SF	12 - 36	85 - 87	-	47	25	1,6

(\*) depending on load conditions - (\*\*) DCc module weight not included (1 module = 3,2kg)

## Modules Chart

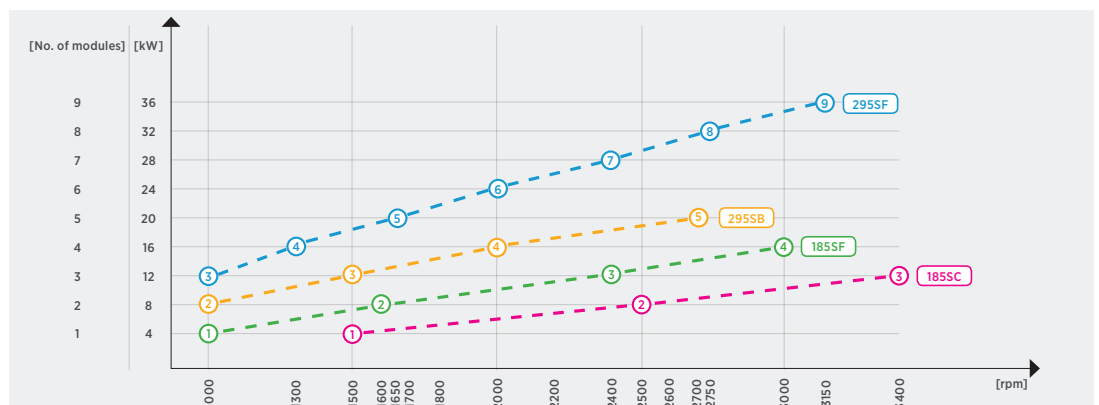

Fully Integrated Ready-to-use System for Telecom

Block Diagrams

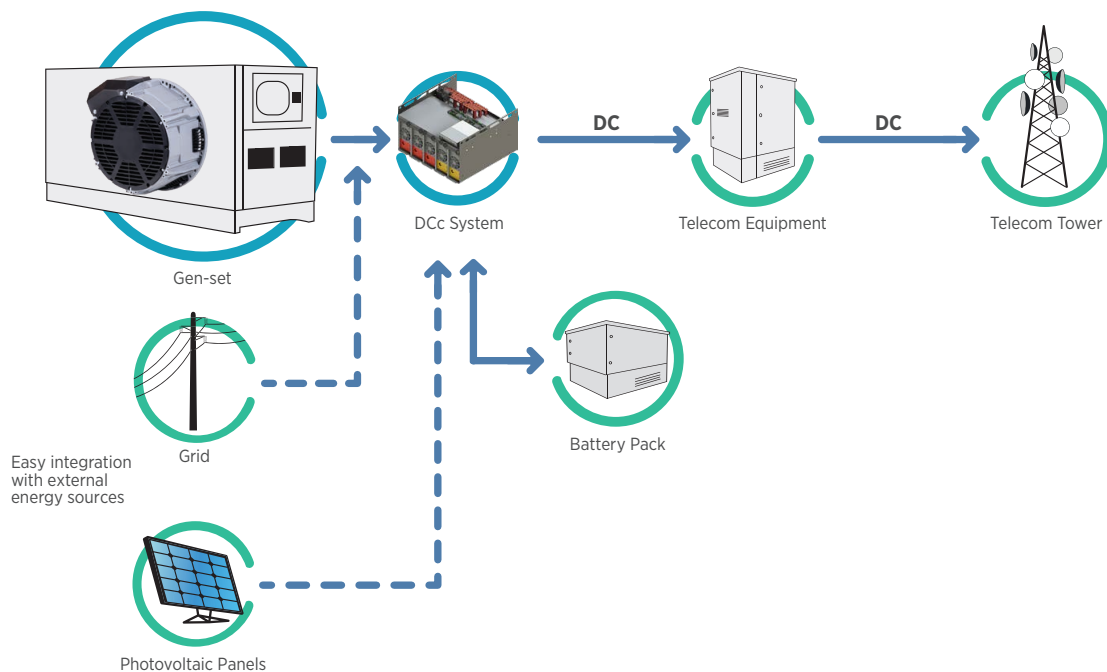
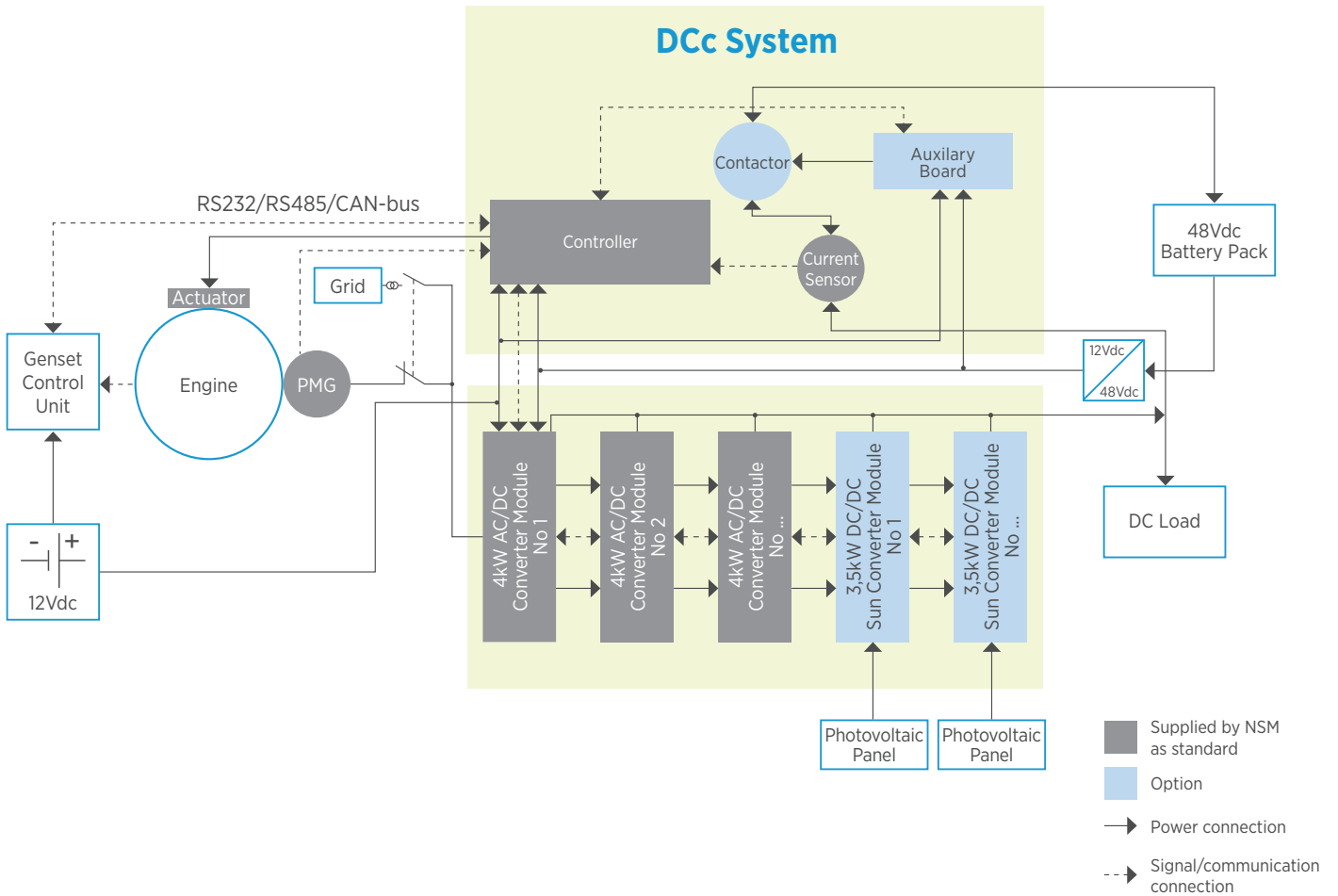

# Fully Integrated Ready-to-use System for Telecom

## Overall Dimensions

### CONE

#### PMG 185

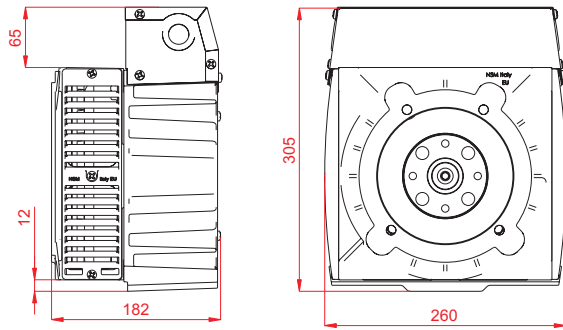

#### J609a

C 19

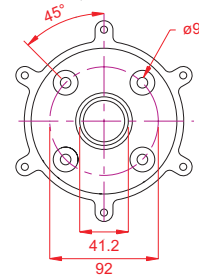
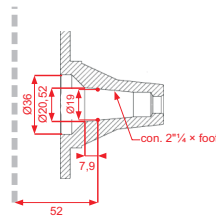

#### J609b

C 25,4

C 35

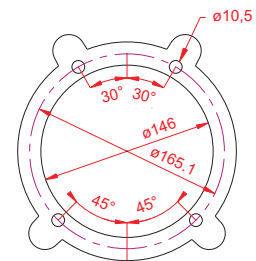
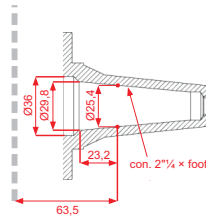

### SAE

#### PMG 185

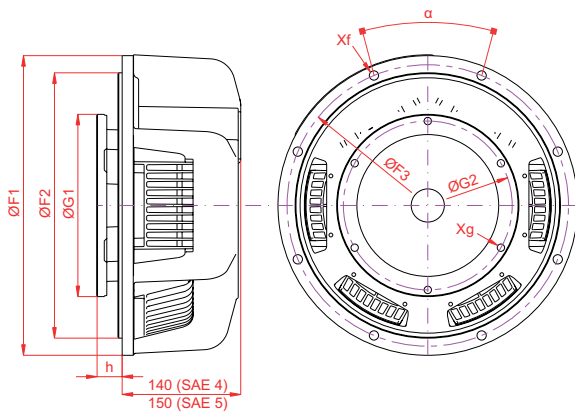

#### PMG 295

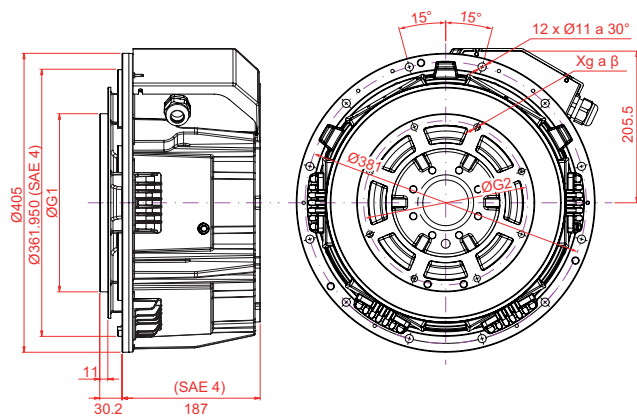

PMG 185	Flange				
	SAE	ØF1	ØF2	ØF3	α
	[mm]				
	5	363	314,33	333,40	45°
	4	403	361,95	381,00	30°

PMG 185	Joint				
	SAE	ØG1	ØG2	h	β
	[mm]				
	6,5	215,90	200,02	30,2	60°
	7,5	241,30	222,25	30,2	45°

PMG 295	SAE			
	6,5	7,5	11,5	
	5	X	X	
4	X	X		
3			X	

PMG 185 SAE 3 and PMG 295 SAE 5 available on request

# Fully Integrated Ready-to-use System for Telecom

## Overall Dimensions

### DCc System

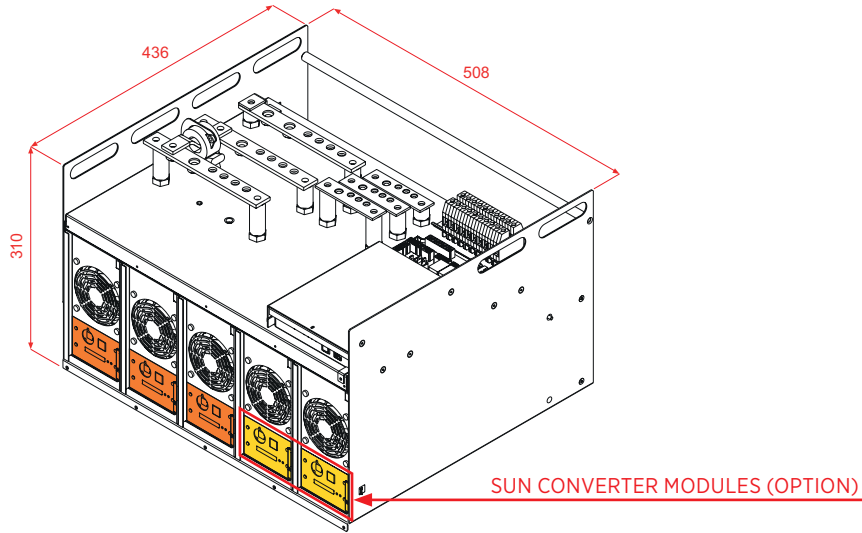

### Linear Actuator

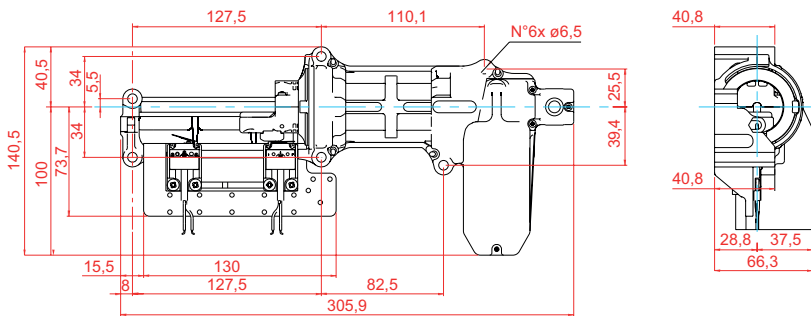

Technical data not binding: NSM reserves the right to modify the contents without prior notice.

**NSM S.r.l.**

Via Lazio 5/b  
36015 Schio | Vicenza | Italy

T +39 0445 595888  
F +39 0445 595800

info@nsmrsl.it  
www.nsmrsl.it

